

# **GTX Project Summary**

**Space Transportation Day  
October 11-12, 2000**

*Space Transportation Technology Workshop*

267

5/14/00

537825  
26

## ***GTX Project Objectives***

- Determine whether or not air-breathing propulsion can enable reusable SSTO
- Provide validated system performance data, and a baseline system design
- Develop technologies applicable to high-speed air-breathing propulsion

# Reusable SSTO Performance Axes

The net benefit of air-breathing propulsion depends on the aero-propulsion and structural performance of the system

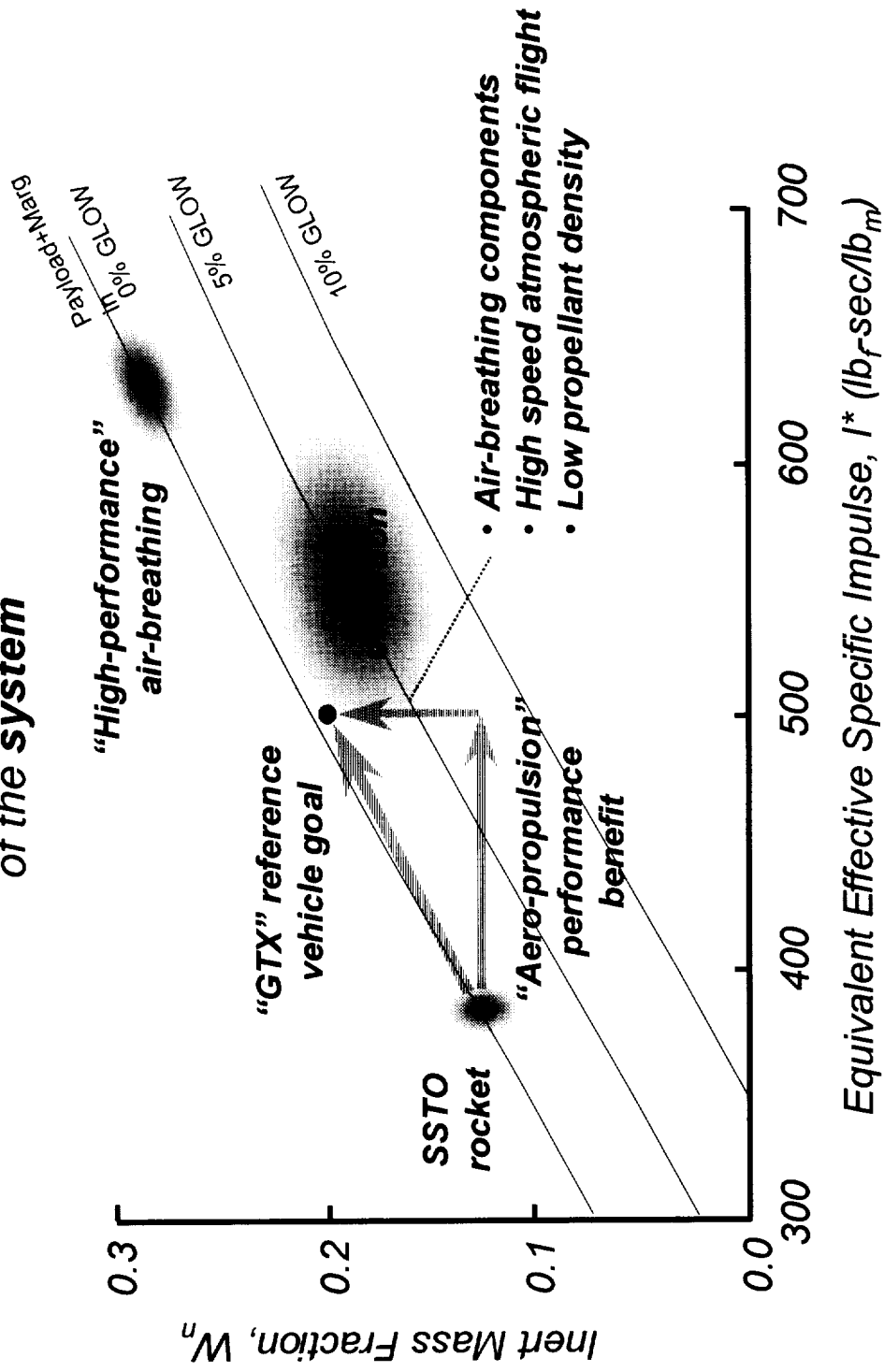

Space Transportation Technology Workshop

# GTX Project

# ***GTX Reference Vehicle Description***

- Reusable, Single-Stage-to-Orbit
- Vertical Lift-Off / Horizontal Landing
- RBCC Propulsion System Operates in 4 Modes
- 500 sec Minimum I\* at Max A/B Mach 11
- 238,000 lb Gross Lift-Off Weight
- LOX/LH2 Propellants
- 300# Payload

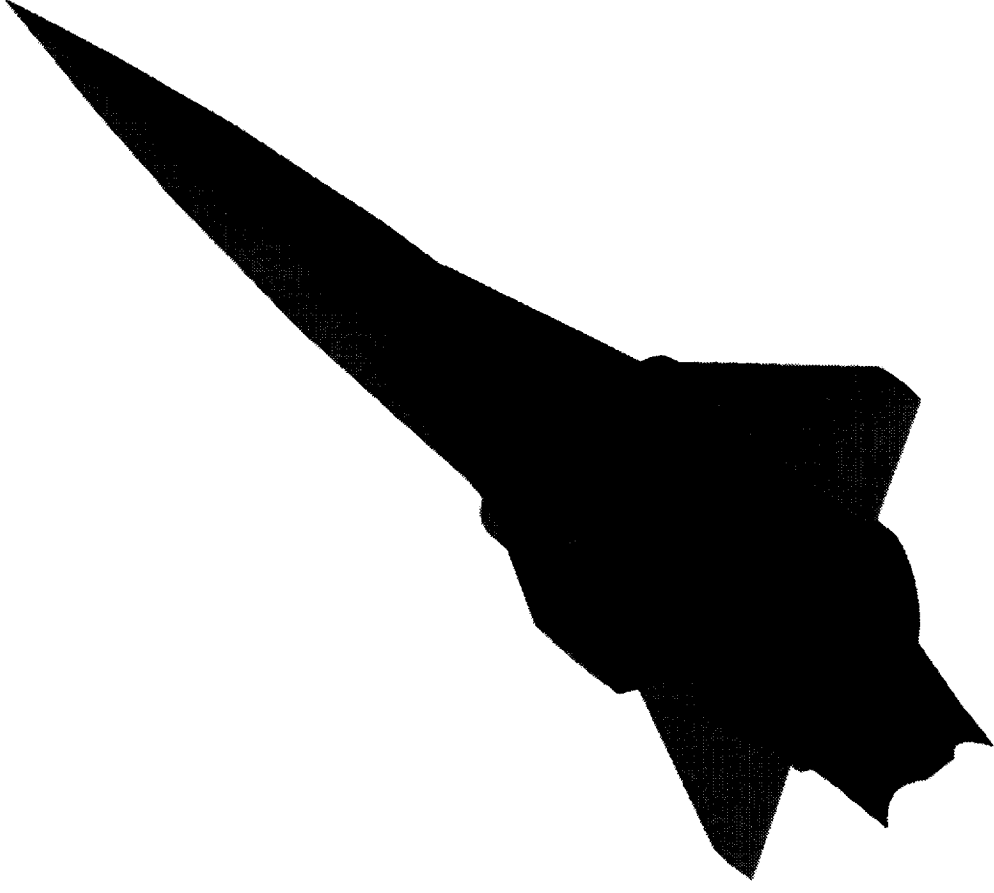

*Space Transportation Technology Workshop*

# **GTX Project**

- ◆ **Independent Ramjet Stream and Simultaneous Mixing and Combustion (SMC) Ejector-Ramjet Cycles Under Consideration**
  - Lower risk, nearer-term than more complex concepts (e.g. SERJ, LACE)
  - Adequate performance for 500 sec  $1^{\text{st}}$  goal at moderate rocket re-ignition Mach number
  - Shorter and lighter than the diffusion and afterburning (DAB) scheme
  - More compatible with rocket mode than other cycles

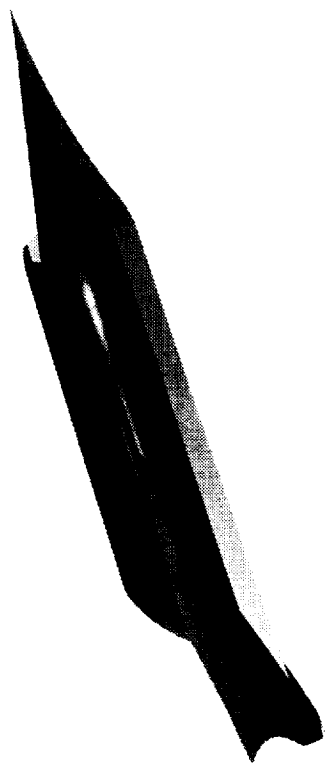

- ◆ **Axi-symmetric Flowpath Configuration**
  - More structurally efficient than 2-D rectangular
  - Reduced design and analysis risk
- ◆ **Mixed-Compression, Translating Centerbody Inlets**
  - Provides required throat area variation, and flowpath close-off for rocket mode
  - Existing design database
  - Minimal sealing issues

# **GTX RBCC Propulsion System**

Space Transportation Technology Workshop

## **Features**

# Planned Flowpath Development Test Rigs

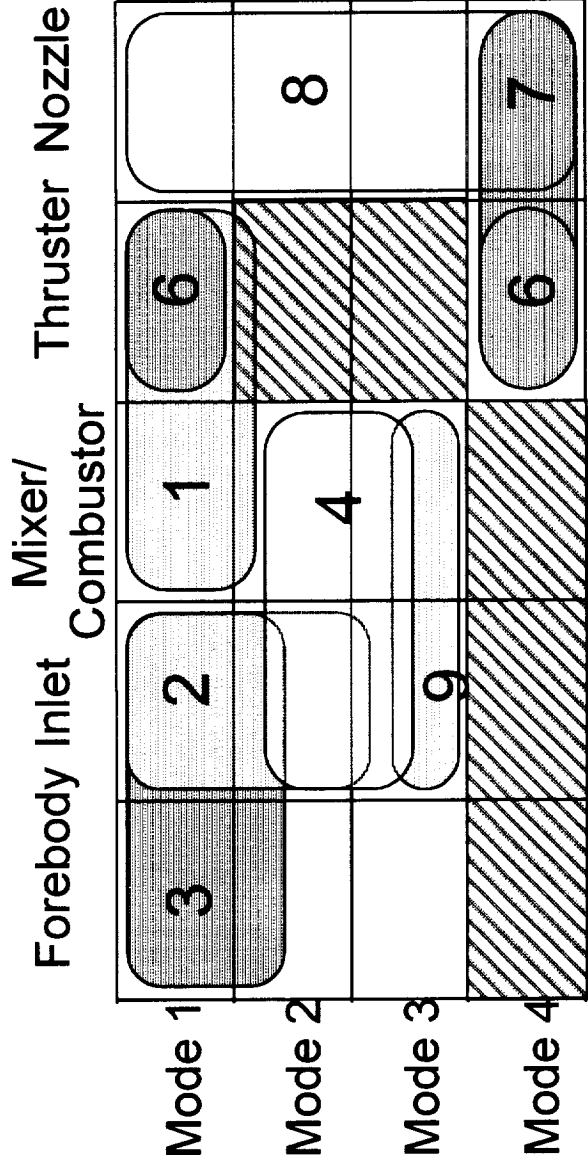
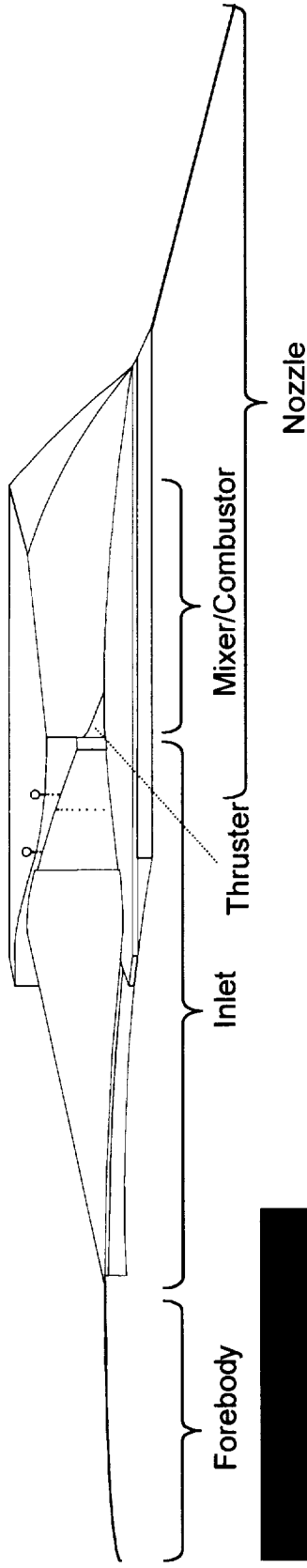

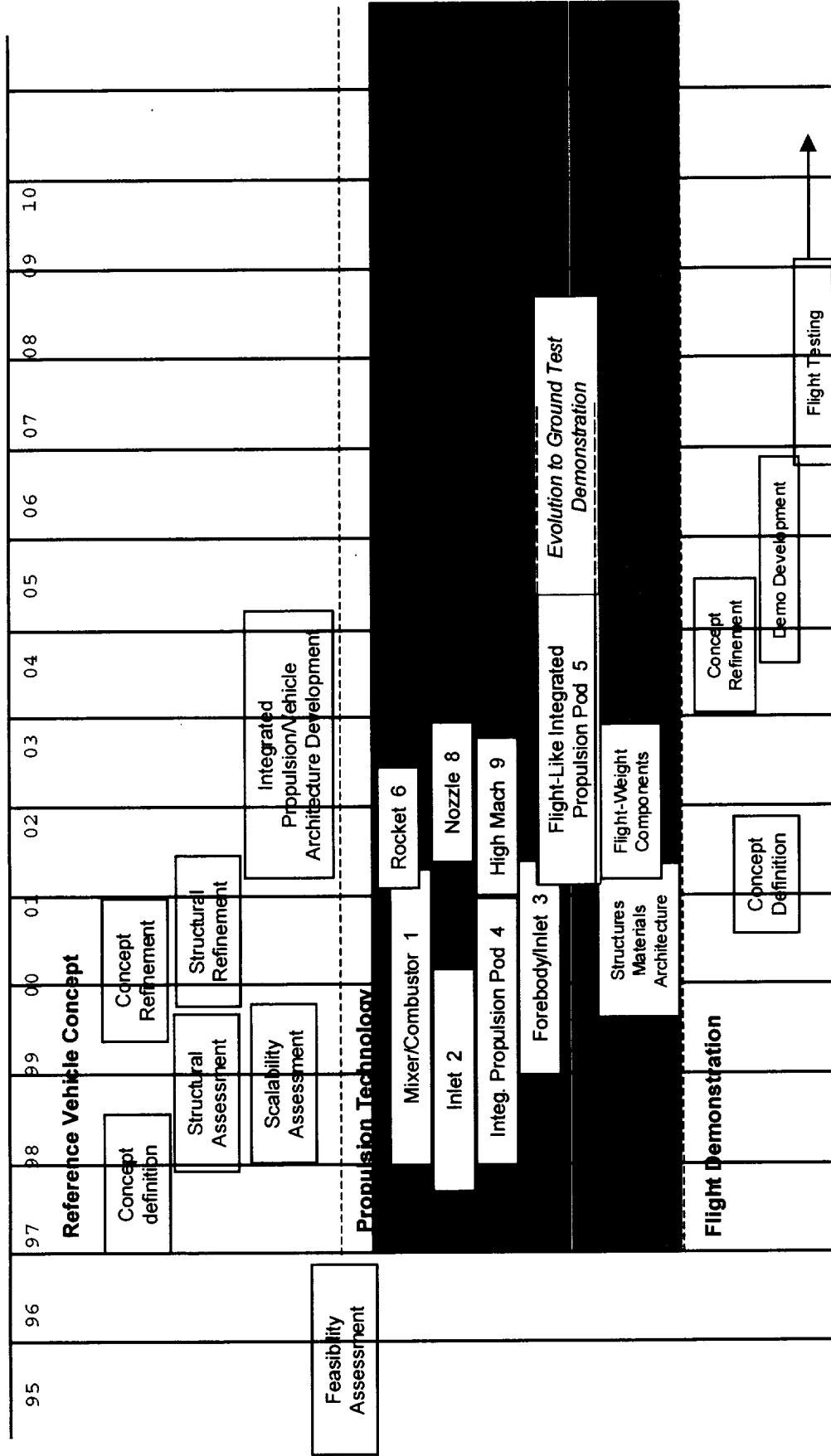

Numbers refer to GTX rig numbers

Space Transportation Technology Workshop

# GTX Project Plan Overview

# **For More Information on GTX**

**Come to the GTX Session  
at the**

**JANNAF 25th Airbreathing Propulsion  
Subcommittee Meeting  
November 13-17, 2000  
Monterey, California**



## **Process and Material Development for Fabrication of CMC Blisks**

J. Kiser, 216-433-3247, [James.D.Kiser@grc.nasa.gov](mailto:James.D.Kiser@grc.nasa.gov)

CMC Blisk



- FY 01: CMC Blisk Project outlined and initiated**
- FY 03: Provide simple shape CMC disks to CCT**
- FY 06: Smooth blade surface technology demonstrated**
- FY 06: Demonstrate 12" diameter, 3" thick high strength disks**

## **High Conductivity Materials**

D. Ellis, 216-433-8736, [David.L.Ellis@grc.nasa.gov](mailto:David.L.Ellis@grc.nasa.gov)

Thrust Cell Liner



- FY 01: Complete experimental design for Cu-alloy development**
- FY 02: Complete screening of advanced copper alloys**
- FY 03: Determine feasibility of very high conductivity Metal Matrix Composites**
- FY 05: Determine mechanical and thermal properties of MMC's**
- FY 06: Demonstrate advanced alloy coating combination via hot fire testing**

*Space Transportation Technology Workshop*

# **Tasks and Milestones**

### **CMC Cooled Components**

M. Jaskowiak, 216-433-5515

Martha.H.Jaskowiak@grc.nasa.gov

Actively-Cooled CMC Panel

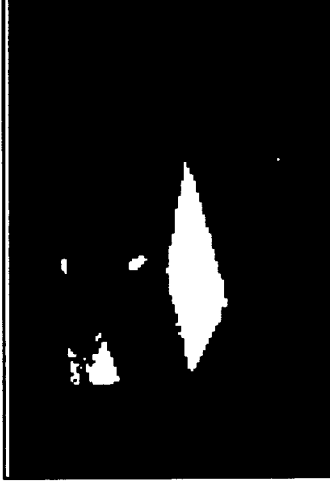

**FY 01:** Heat exchanger concepts and uncooled concepts selected

**FY 03:** Thermal performance tests of first concepts

**FY 05:** Aeroconvective tests of first concepts

### **Polymers and PMC's for High Temperature Propulsion Applications**

M. Meador, 216-433-9518, Michael.A.Meador@grc.nasa.gov

**FY 02:** Demonstrate RTM processable polymer for use at 550F

**FY 03:** Demonstrate high temperature polymer nanocomposites with improved mechanical properties and reduced gas permeability

**FY 04:** Develop and demonstrate polymers and PMCs with durability at 750°F

**FY 05:** Demonstrate enhanced cryogenic toughness and durability of high temperature PMCs

**FY 06:** Demonstrate affordable PMC for 750°F applications

## **CMC's for Static Propulsion Components**

M. Freedman, 216-433-3284

Marc.R.Freedman@grc.nasa.gov

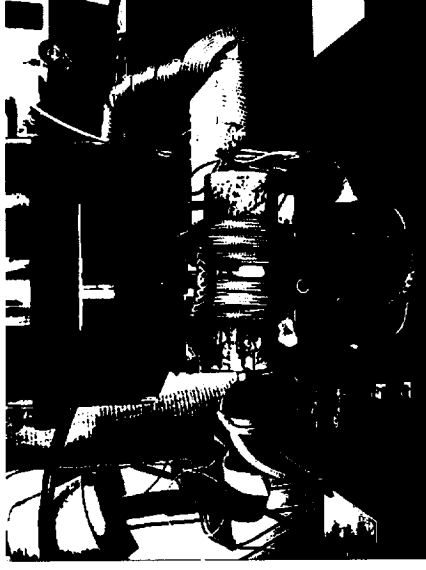

- FY 01: Baseline materials characterized**
- FY 03: Screening capabilities updated**
- FY 05: Fiber architecture model verified**
- FY 07: Knowledgebase established**

## **Ceramic Composite Thrust Chamber Development**

J. Lang, 216-433-6675, Jerry.Lang@grc.nasa.gov

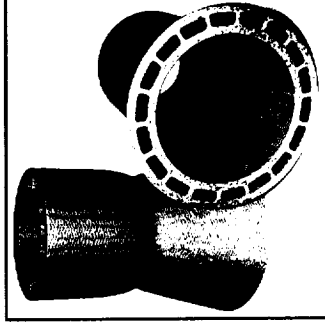

- FY 01: Define and characterize CMC thrust chamber subelements**
- FY 03: Screen uncooled concepts for thrust chambers (RCS Scale)**
- FY 05: Screen regeneratively cooled concepts for thrust chambers**

## **Cooled Leading Edge Concepts**

D. Glass, 757-864-5423, d.e.glass@larc.nasa.gov

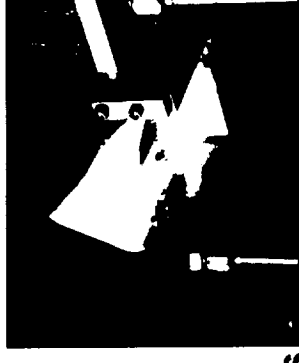

- FY 01: Complete survey of Gen 3 vehicle needs for leading edges**
- FY 02: Fabricate subcomponent test articles for leading edges**
- FY 03: Test leading edge subcomponents in challenging aerothermal environment**
- FY 04: Identify leading edge with 2X life compared with FY 00**
- FY 06: Identify leading edge with 5X life compared with FY 00**

## **National Durability Test Apparatus**

L. Greenbauer-Seng, 216-433-6781,  
Leslie.A.Greenbauer-Seng@grc.nasa.gov

- FY 01: Examine industry critical materials needs based on selected Gen 3 engines**
- FY 01: Initiate design of quick access test rig**
- FY 01: Initiate construction of low cost, low fidelity test rig**
- FY 03: Construct higher fidelity quick access rig**
- FY 04: Operate Quick Access rig for government and industry materials evaluation**

# **RLV 3<sup>rd</sup> Generation Supplemental Slides**

**The following slides provide additional information  
on select RLV 3<sup>rd</sup> Generation Long Life, Light  
Weight Materials Tasks**

### **Goals and Objectives:**

- Improve the durability, reliability, performance and affordability of polymer matrix composite propulsion components for space transportation systems

### **Background**

- Current high temperature PMCs have poor long-term stability at temperatures above 650°F, poor durability at cryogenic temperatures and high manufacturing costs

### **Current Status/Major Accomplishments:**

Recent work at GRC has led to:

- Solvent based low cost manufacturing (saRTM) for use with 650 -700°F PMCs
- RTM processable PMCs for use at temperatures up to 500°F
- High temperature clay/polymer nanocomposites
- Improved understanding on the durability of braided PMC structures

### **Near Term Milestones:**

- Demonstrate RTM processable 550°F polymer for propulsion applications (FY02)
- Develop/demonstrate high temperature polymer nanocomposite with improved mechanical properties and reduced gas permeability (FY03)
- Develop/demonstrate polymers and PMCs with durability at 750°F (FY04)
- Demonstrate enhanced cryogenic toughness and durability of high temp PMCs (FY05)
- Demonstrate affordable 750°F PMC (FY06)

### **Point of Contact:**

Michael A. Meador, (216) 433-9518, Michael.A.Meador@grc.nasa.gov

*Space Transportation Technology Workshop*

# **Polymers and Polymer Matrix Composites for Propulsion Components**

**BLANCHING : Generation of Interconnected Porosity from Cycles Between Oxidizing & Reducing Environments**



**COATINGS SYSTEMS FOR  
BLANCHING PROTECTION**

- CURRENT:** NiCrAlY SYSTEMS
- GEN-2:** Cu-Cr SYSTEMS
- GEN-3:** NON-Cr<sub>2</sub>O<sub>3</sub>-FORMING SYSTEMS

- ◆ **Coatings can prevent environmental attacks such as blanching**
- ◆ **Advanced coatings can reduce hot wall temperature**
- ◆ **Both increase liner life and decrease operating expenses**

*Space Transportation Technology Workshop*

# **Coatings For Thrust Cell Liners**



### Diamond

- Thermal Conductivity – 2000 W/mK
- Hardest known substance

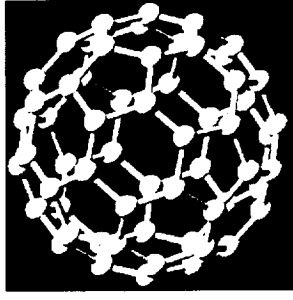

### Buckyballs

- Unknown thermophysical properties
- Potentially very hard/strong
- May be chemically modified



### Carbon Nanotubes

- Similar structure and properties to Buckyballs
- Long range potential to make fiber reinforced composites

Combined with a copper matrix, these particulates/fibers could produce low thermal expansion, ultra-high conductivity, high strength composites



**Safe Life Propulsion Design Technologies**  
**(3rd Generation Propulsion Research & Technology)**

**Rod Ellis**  
**NASA Glenn Research Center**

**2<sup>nd</sup> Annual Space Transportation Day, October 11-12, 2000**  
**Marshall Space Flight Center, Huntsville, Alabama**

*Space Transportation Technology Workshop*

## 3<sup>rd</sup> Generation Propulsion R&T Project

### Task Titles

- Ceramic matrix composite (CMC) life prediction methods.
- Life Prediction methods for ultra high temperature polymer matrix composites for RLV airframe and engine application.
- Enabling design and life prediction technology for cost effective large-scale utilization of MMCs and innovative metallic material concepts.
- Probabilistic analysis methods for brittle materials and structures.
- Damage assessment in CMC propulsion components using nondestructive characterization (NDC) techniques.
- High temperature structural seals for RLV application.

*Space Transportation Technology Workshop*

## **Safe Life Propulsion Technologies**

# Ceramic Matrix Composite (CMC) Life Prediction Methods (P-5-Ellis-2-t)

## POC: Rod Ellis/5900, Stan Levine/5100

### Goals/Objectives

To advance current empirically based life models to allow for the

- Ability to account for environmental effect on life.
- Ability to predict life for combined loads.
- Ability to predict component life.

### Technical Challenges

- Understanding the physics of mechanical and environmental damage mechanisms leading to eventual material failure.
- Integrating environmental, micro-mechanics and macro-level damage models into a unified engineering design tool.

### Approach

- Coordinated effort with sub-tasks addressing:
- Probabilistically based, macro-level, residual strength life model.
- Engineering mechanics model at the fiber/matrix level.
- Identification and modeling of governing chemistry of environmental attack and life extension methods.
- Generation of a robust lifting database characterizing the effect of environmental state variables (temperature, oxygen, and steam) on material strength degradation.

CMC are enabling for aerospike, advanced turbopumps, airbreathing



propulsion concepts, and airframe TPS and hot structure applications.

### Milestones

- Initiate procurement of CMCs (C/SiC, SiC/SiC) panels for coupon-level tests supporting development of life prediction methods, 1QFY01.
- Complete initial series of mechanical/thermomechanical tests supporting development of life prediction models, 4QFY02.
- Complete development of models characterizing key damage mechanisms in CMCs under oxidizing and steam-rich environments, 4QFY03.
- Complete development of CMC life prediction models including the combined effects of thermal/mechanical loading and environmental property degradation, 4QFY04.
- Complete development of life enhancing environmental coatings and thermal barrier coatings and publish results, 4QFY05.
- Complete subcomponent tests and use results to verify/validate the performance of CMC lifting methods in predicting behavior under complex stress states and service environments 4QFY06.

*Space Transportation Technology Workshop*

# Safe Life Propulsion Technologies

# Life Prediction Methods For Ultra High Temperature (UHT) Polymer Matrix Composites (PMC) For RLV AirFrame and Engine Application (P-5-Ellis-1-t)

POC: Rod Ellis/5900, Mike Meador/5100

## Goals/Objectives/Benefits

- Develop physics-based life prediction methods: Successful development is enabling given the need for safe, reliable, cost-effective Reusable Launch Vehicles.
- Support development of low-cost PMC: Fully optimized and tailored PMC materials will lead to highly efficient airframe and propulsion components.
- Develop comprehensive data bases for candidate UHT PMC: Data bases determined with Design of Experiments (DOE) methodology will lead to increased reliability and will support probabilistic analysis.
- Support development of advanced UHT PMC incorporating nanotechnology: Revolutionary gains in performance and reliability expected from this new class of materials.
- Develop new NDE techniques for UHT PMC incorporating nanotechnology: Successful development of NDE technology is key to assuring quality.
- Perform subcomponent tests to verify methodologies: Test will be conducted on composites in scaled-up form produced using low-cost manufacturing methods.

## Approach

- **Critical screening tests** will be conducted at GRC and AFRL/WPAFB on candidate PMC to evaluate material integrity and reusability under extreme thermo-mechanical loading conditions. Particular attention will be given to the role of heat rates, water, steam, and other limiting RLV environments.
- **Comprehensive data bases** will be generated for down selected materials at GRC and under contract focusing on standard mechanical properties. Also, nonstandard properties such as stiffness retention and residual strength will be determined in support of life prediction model development.
- **Physics-based life prediction models** will be developed which accurately model the damage mechanisms and failure mechanisms observed in the experimental studies. The analytical modeling effort will be pursued at GRC and at Georgia Tech.
- **Subcomponents** will be fabricated using low-cost manufacturing methods by well-established contractors and tested under prototypical loading conditions at MSFC. The analytical predictions of subcomponent deformation and fatigue behavior will be made at GRC using the advanced life prediction methods fully implemented into finite element codes.

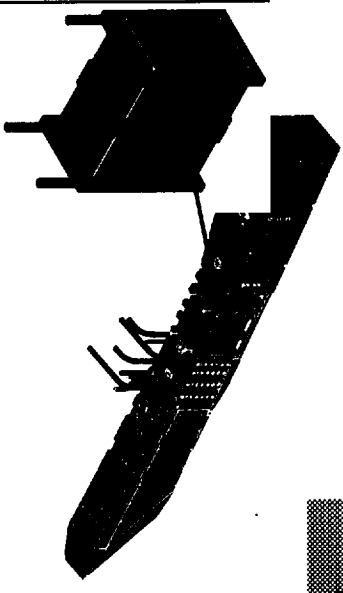

## RBCC Manifolds & Support Structure

### Technical Challenges

- Low Cost Manufacture
- Complex Environmental Issues
- Complex Deformation / Damage Mechanisms
- Uncertainties Associated With Nanotechnologies

### Milestones

- Complete screening study of UHT PMCs with optimized 3D fiber architectures with the focus on moisture absorption and behavior under rapid thermal transients, 4QFY01.
- Complete development of continuum damage mechanics (CDM) model accounting for viscoelasticity and microcracking and publish results, 2QFY02.
- Complete initial series of coupon-level mechanical/thermomechanical tests supporting development of life prediction methods, 4QFY02.
- Complete development of PMC life prediction models including the combined effects of thermal/mechanical loading and environmental property degradation, 4QFY03.
- Complete initial screening tests on UHT PMCs with properties enhanced using nanocomposite technology, 4QFY04.
- Complete subcomponent test and use results to verify/validate the performance of PMC firing methods in predicting behavior under multiaxial stress states and service environments 4QFY06.

*Space Transportation Technology Workshop*

# Safe Life Propulsion Technologies

# Enabling Design and Life Prediction Technology for Cost Effective Large-Scale Utilization of MMCs and Innovative Metallic Concepts (P-5-Arnold-1-t)

POC: Steve Arnold (5900), Mike Nathal (5100)

## Goals/Objectives

- Develop/mature the accurate multi-scale structural analysis and life prediction technology required to **enable full deployment of MMCs** and other advanced metallic concepts in 3<sup>rd</sup> generation RLVs
  - Significantly improve component safety and reliability
  - Dramatically decrease costs associated with both design/development and component life-cycles
- Empower materials scientists to **design the advanced metallic materials** systematically for cost-effective implementation in RLV applications
- Empower structural engineers to **design with the advanced metallic materials** on all relevant scales to exploit the full potential of these materials

## Technical Challenges

- **Deformation Modeling:** Enhance physically-based multi-mechanism models and include environmental effects
- **Damage Modeling:** Identify/develop accurate strength and stiffness reduction continuum damage models
- **Thermomechanical Testing:** Obtain quality materials and develop appropriate test methods for both characterization and verification
- **Material Parameter Estimation:** Mature/verify technology for rapid parameter estimation with minimal testing
- **Homogenization/Localization Techniques:** Develop/verify techniques with improved accuracy and functionality
- **Local/Global Failure Analysis:** Identify/develop multi-scale life prediction methodologies for actual component thermomechanical environments
- **Model Synthesis:** Enable design/analysis on all scales (constituent → structure) while optimizing computational efficiency

## Approach: Multi-scale Modeling of MMC's

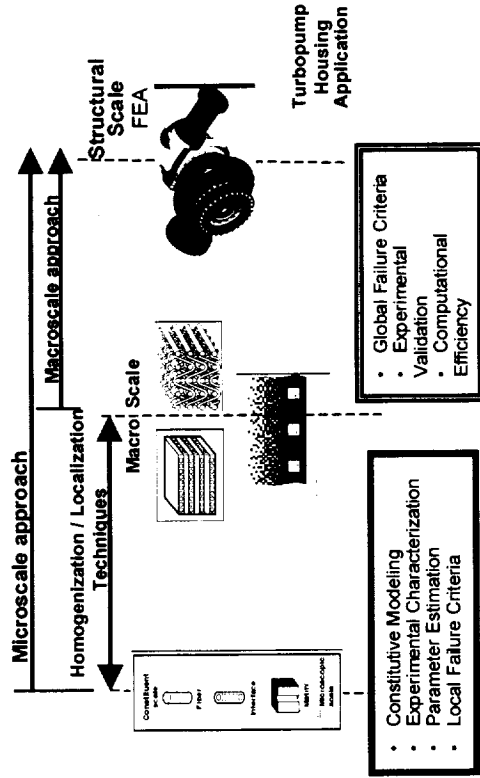

## Milestones

- Identify & procure "model" discontinuous reinforced metallic composite material & associated matrix material, 2QFY01.
- Release enhanced version of MAC/GMC incorporation among other things the new multi-mechanism viscoelastoplastic deformation & damage model, 3QFY01.
- Perform series of exploratory coupon level tests to identify key deformation & damage mechanisms in discontinuous reinforced metallic material, 4QFY01.
- Develop & incorporate into MAC/GMC a high fidelity micromechanics-based formulation accounting for shear-coupling, 4QFY02.
- Perform coupon level deformation  $\gamma$  life tests under biaxial loading, 4QFY03.
- Perform a multiscale analysis of a fiber/particulate reinforced subcomponent incorporating appropriate local/global failure criteria, 4QFY05.
- Perform subcomponent testing under complex multiaxial states of stress, 4QFY06.

Space Transportation Technology Workshop

# Safe Life Propulsion Technologies

# Probabilistic Analysis Methods for RLV Propulsion Materials & Structures (P-5-Nemeth/Pai-1-t)

POC: Rod Ellis (5900), Stan Levine (5100)

## Goals/Objectives

- ◆ Develop advanced probabilistic design and analysis methods for "brittle" materials and structures with the focus on:
- ◆ Reliable analysis methods for micro-electromechanical (MEMs) devices and systems
- ◆ Efficient methods for optimizing and tailoring composite materials
- ◆ More efficient structural design processes resulting in improved component reliability and reduced cost

## Technical Challenges

- ◆ Account for the highly stochastic nature of damage accumulation and failure in brittle materials and structures and account for demanding service environments including:
- ◆ Foreign object damage (FOD)
- ◆ Complex environmental effects
- ◆ Extreme thermomechanical loading conditions
- ◆ Complex dynamic loading conditions

## Approach: Multi-scale Modeling of MMC's

- ◆ Extend probabilistic analysis methods developed at GRC for aeronautics applications (CARES/LIFE, NESSUS) to RLV applications and materials.
- ◆ Team from the outset with industry partners to ensure the design tools developed fully meet the needs of the space propulsion design community.
- ◆ Ensure that the probabilistic life prediction methods developed are physics-based and take proper account of environmental effects.
- ◆ Ensure that the probabilistic analysis methods developed are computationally efficient and are fully compatible with "industry standard" finite element analysis codes.

## Candidate RLV Components

- ◆ Propulsion components including:
  - nozzle injectors
  - exit cones
  - throats
- ◆ Thermal protection system
  - sharp leading edges
- ◆ Engine sensors
  - Microelectromechanical Systems



Silicon Nitride  
Rocket  
Thruster

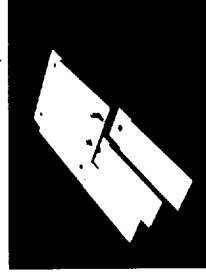

Ultra-High-Temperature Ceramic  
for RLV Leading Edges

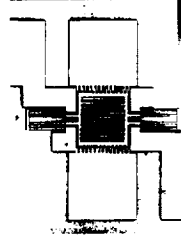

MEMS Sensors

## Milestones

- ◆ Complete beta testing of ANSYS version 5.7 with probabilistic design system (PDS) options [4QFY01]
- ◆ Modify CARES/Life to simulate geometry/material property variations using ANSYS (PDS) and establish effect on life prediction [4QFY02]
- ◆ Complete extension of probabilistic residual strength model for MMCs (C/SiC, SiC/SiC) to multiaxial stress states and variable amplitude loading [4QFY03]
- ◆ Complete probabilistic modeling of MEMS and electronic structures under prototypical loading conditions and harsh environments [4QFY04]
- ◆ Complete integration of probabilistic life prediction models with propulsion health monitoring system [4QFY06]

*Space Transportation Technology Workshop*

# Safe Life Propulsion Technologies

# CMC Life Determination Using Nondestructive Characterization Techniques

## P-5-Effinger-FTP-1

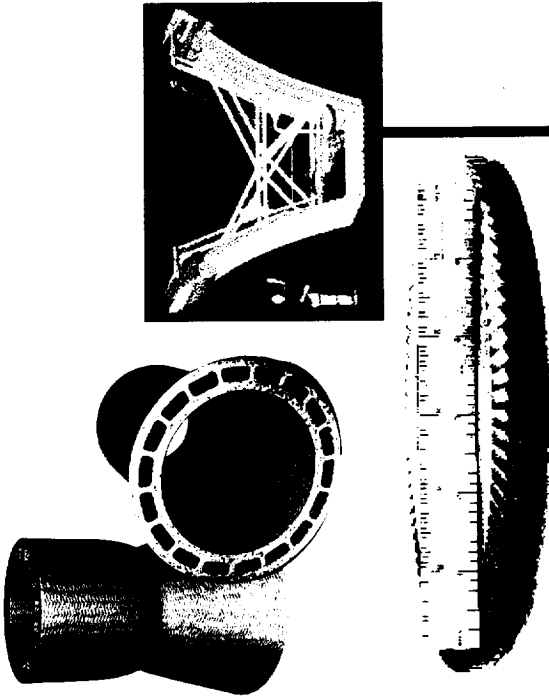

### Milestones/Activities

- ◆ **FY'01 Milestones**
  - Complete Simplex blisk fatigue testing
  - Establish correlation of NDC data of fatigued coupons to NDC data of fatigued CMC blisk
- ◆ **FY'02 Milestones**
  - University and industry contracts awarded
  - Synergistic NDC Life Prediction plan with AF, DOE, and NASA generated
- ◆ **Prioritized list of Activities**
  - Synergistic plan with Foundation's P-5-Kiser-1
  - Multi-axial & attachment testing data

### Implementation Metrics

- ◆ **Current State of the Art**
  - physics base life *prediction* with no real-time life *determination* potential
- ◆ **Performance Metrics**
  - Feasibility path defined, milestones met
- ◆ **Risks**
  - Environmental degradation determination by NDC, development of tools/mode to predict CMC life with NDC determined properties, NDC discernment of different aspects of material degradation.
- ◆ **Participants**
  - NASA: GRC, MSFC, Industry: Honeywell, SoRI, Univ. of HI, IL @ Chicago, OAI, Cleveland State, others

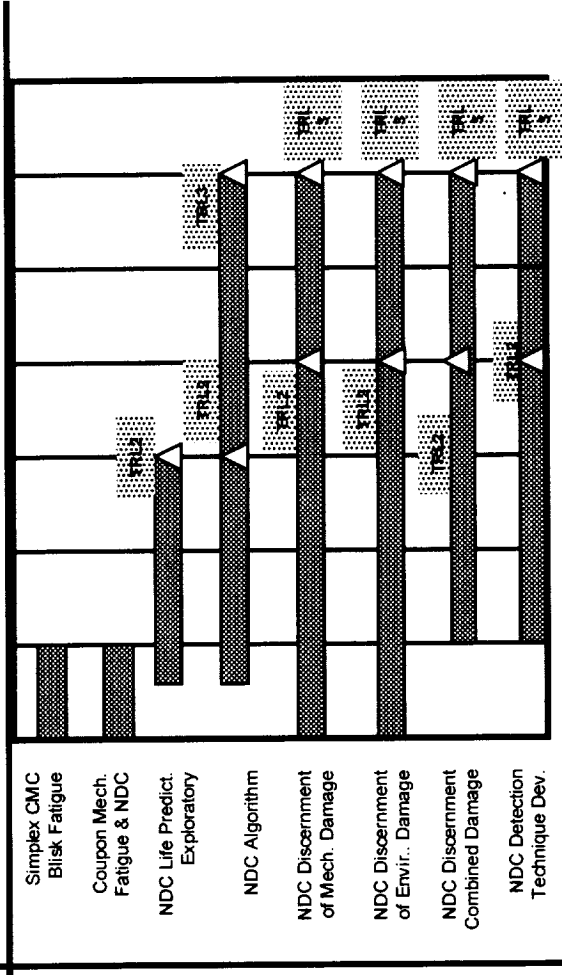

Space Transportation Technology Workshop

# Safe Life Propulsion Technologies

# Advanced Structural Seals for Propulsion Systems

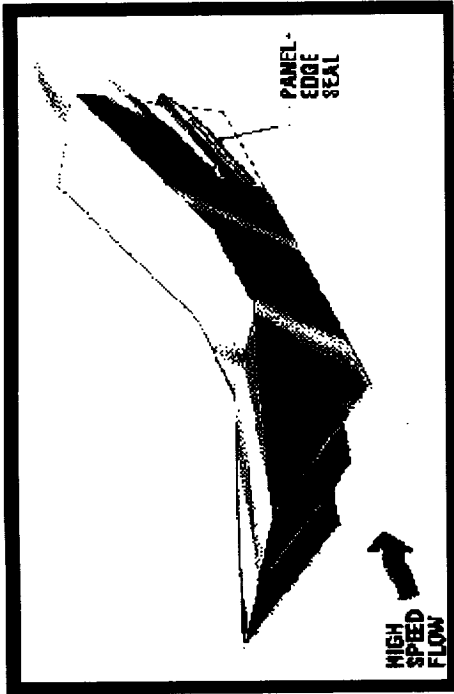

RBCC or TBCC Inlet/Nozzle Ramp Seals

## Implementation / Metrics

- Current State of the Art
  - Limited NASP engine seals & database
  - No known 2000-2500°F dynamic re-usable structural seals
- Performance Metric
  - Re-usable seals tested under relevant env.
- Risks
  - Facility availability for hot thermal/mechanical/acoustic tests
  - Materials with inadequate perf. capabilities
- USG Participants: GRC Lead.
- POC: Dr. Bruce M. Steinetz NASA GRC  
bruce.steinetz@grc.nasa.gov (216) 433-3302

## Products / Benefits

- Milestones
  1. Preliminary seal concepts identified FY01
  2. Unique performance test fixture fabrication complete FY02
  3. Seal thermal structural analyses complete FY02
  4. Hot resiliency/scrub critical function tests comp. (Gen 1 seals) FY03
  5. Hot resiliency/scrub critical function tests comp. (Gen 2 seals) FY04
  6. Rocket heating/ Thermal Survival Tests Complete FY05
  7. Thermal/acoustic tests complete FY06

## • Prioritized list of Activities

Define requirements and seal concepts; Perform seal thermal-structural analyses  
 Design/fabricate test apparatus to measure seal performance  
 Conduct perf. tests: flow, compression, rocket heating, thermal/acoustic (as applicable)

## Document seal design guidelines

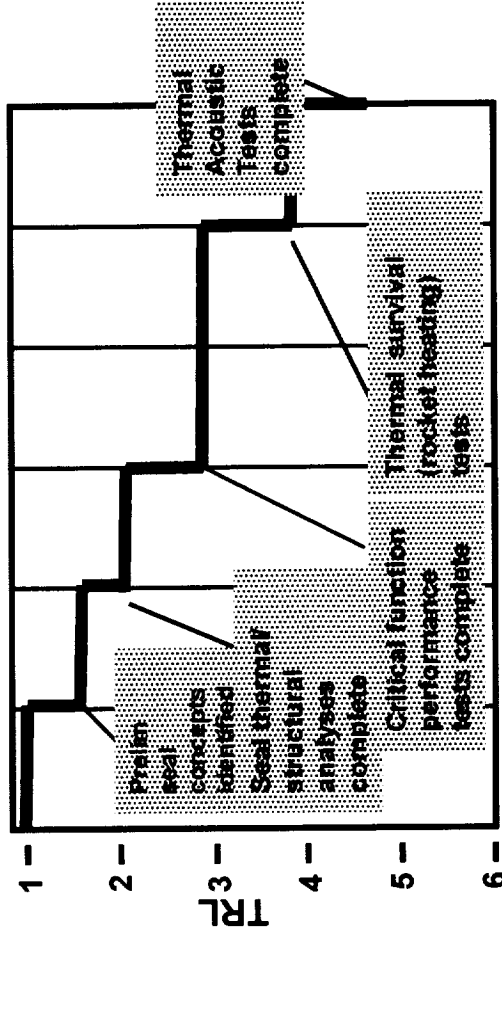

Space Transportation Technology Workshop

# Safe Life / Foundation Technologies



## **STATUS/FUTURE WORK**

- Ceramic Matrix Composite (CMC) Life Prediction Methods
  - Initiate procurement of CMCs (C/SiC, SiC/SiC) panels for coupon-level tests supporting development of life prediction methods, [1QFY01].
  - Complete initial series of mechanical/thermomechanical tests supporting development of life prediction models, [4QFY02].
- Life Prediction Methods for Ultra High Temperature (UHT) Polymer Matrix Composites for RLV Airframe and Engine Application
  - Complete screening study of UHT PMCs with optimized 3D fiber architectures with the focus on moisture adsorption and behavior under rapid thermal transients, [4QFY01].
  - Complete development of continuum damage mechanics (CDM) model accounting for viscoelasticity and microcracking and publish results, [2QFY02].
- Enabling design and life prediction technology for cost effective large-scale utilization of MMCs and innovative metallic material concepts.
  - Initiate procurement of advanced metallics including particulate and fiber reinforced composite materials, [1QFY01].
  - Release enhanced version of MAC/GMC incorporating latest multi-mechanism viscoelastoplastic deformation and damage model, [3QFY01].

*Space Transportation Technology Workshop*

# **Safe Life Propulsion Technologies**

## **STATUS/FUTURE WORK**

4. Probabilistic analysis methods for brittle materials and structures.
  - Complete beta testing of ANSYS version 5.7 with probabilistic design system (PDS) options, [4QFY01].
  - Modify CARES/Life to simulate geometry/material property variations using ANSYS (PDS) and establish effect on life prediction, [4QFY02].
5. Damage assessment in CMC propulsion components using nondestructive characterization (NDC) techniques.
  - Complete simplex blisk fatigue testing, [4QFY01].
  - Establish correlation of NDC data of fatigued coupons to NDC data of fatigued CMC blisk, [4QFY01].
- High temperature structural seals for RLV application.
  - Preliminary seal concepts identified, [4QFY01].
  - Complete fabrication of unique performance test fixture, [4QFY02].